

Special Plastic Chain

Series **uni 882** Type **Tab SC**

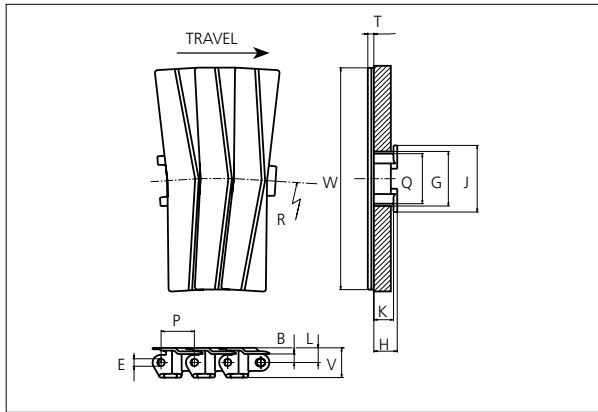

Special Plastic Chain
 Side flexing chain
 Pitch: 38.1 mm (1.50 in)
 Backflex radius: 125.0 mm (4.90 in)
 Permissible tensile strength:
 POM material: 4000 N (899 lbf)

 Delivery: 3.048 m (10 ft)
 No. of links/box: 80

STANDARD

B		E		G		H		J		K		L		P		Q		T		V	
mm	in	mm	in	mm	in	mm	in	mm	in	mm	in	mm	in	mm	in	mm	in	mm	in	mm	in
9.7	0.38	8.7	0.34	59.5	2.34	21.9	0.86	76.2	3.00	17.5	0.69	16.7	0.66	38.1	1.50	57.2	2.25	7.0	0.28	29.0	1.14

All dimensions are for chains in POM material.

	Width (W)		Material & color	Pin material	Weight		min. radius R	
	mm	in			kg/m	lb/ft	mm	in
K450	114.3	4.50	POM-LF BR	SS304	2.2	1.48	610	24.02
K750	190.5	7.50	POM-LF BR	SS304	3.0	2.01	610	24.02
K1000	254.0	10.00	POM-LF BR	SS304	3.4	2.28	610	24.02

Non standard material and color: See uni Material and Color Overview.
 Non standard pin material: See uni Material and Color Overview.

SIDE FLEXING

PITCH 38.1 MM/1.50 IN

Any questions? Please contact us.

Sprocket

No of teeth	Pitch diameter		Overall-diameter		Min. ø bore		Max. ø bore		Hub-diameter		A-dimension		B-dimension		Molded PA66 LG	Molded Cast Iron	Machined PA66
	mm	in	mm	in	mm	in	mm	in	mm	in	mm	in	mm	in			
Z9	111.4	4.39	112.7	4.44	20.0	0.79	45.0	1.77	60.0	2.36	62.0	2.44	73.3	2.89	x	x	
Z10	123.3	4.85	125.0	4.92	20.0	0.79	45.0	1.77	65.0	2.56	68.3	2.69	79.3	3.12	x	x	
Z11	135.2	5.32	137.4	5.41	20.0	0.79	50.0	1.97	73.5	2.89	74.6	2.94	85.2	3.35	x	x	
Z12	147.2	5.80	150.6	5.93	20.0	0.79	50.0	1.97	73.5	2.89	80.8	3.18	91.2	3.59	x	x	
Z15	183.3	7.22	186.9	7.36	20.0	0.79	50.0	1.97	120.0	4.72	99.3	3.91	109.1	4.30		x	x

Two part sprocket

No of teeth	Pitch diameter		Overall-diameter		Min. ø bore		Max. ø bore		Hub-diameter		A-dimension		B-dimension		Molded PA66 LG	Molded Cast Iron	Machined PA66
	mm	in	mm	in	mm	in	mm	in	mm	in	mm	in	mm	in			
Z9	111.4	4.39	112.7	4.31	20.0	0.79	45.0	1.77	60.0	2.36	62.0	2.44	73.3	2.89	x		
Z10	123.3	4.85	125.0	4.81	20.0	0.79	45.0	1.77	65.0	2.56	68.3	2.69	79.3	3.12	x		
Z11	135.2	5.32	137.4	5.30	20.0	0.79	50.0	1.97	73.5	2.89	74.6	2.94	85.2	3.35	x		
Z12	147.2	5.80	150.6	5.79	20.0	0.79	50.0	1.97	73.5	2.89	80.8	3.18	91.2	3.59	x		

Molded sprocket



Cast iron sprocket



Machined sprocket



Molded two part sprocket



Non standard material and color:
See uni Material and Color Overview.

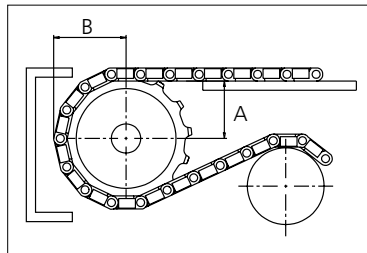

Please ensure that sufficient size shaft and keyway are chosen for corresponding load.

Other sprocket sizes are available upon request
Width of tooth: 22.20 mm/0.87 in
Width of sprocket: 42.3 mm/1.70 in
uni Retainer Rings: See uni Retainer Ring data sheet